



HLPW6: RANS TFG

Fidelity Pointwise Grid Generation Efforts

Reza Djeddi (Principal CFD Application Engineer), **Mike Malone** (Senior Principal CFD Application Engineer)
Carolyn Woeber (Application Engineering Director), **Nick Wyman** (Software Engineering Group Director)

February 11, 2026

cādence[®]

HLPW6

Test Case 1: CRM-HLS

- Simplified High-Lift Configuration with a full span slat and a partial span flap
- Free air at 3.55 million Re_{MAC}

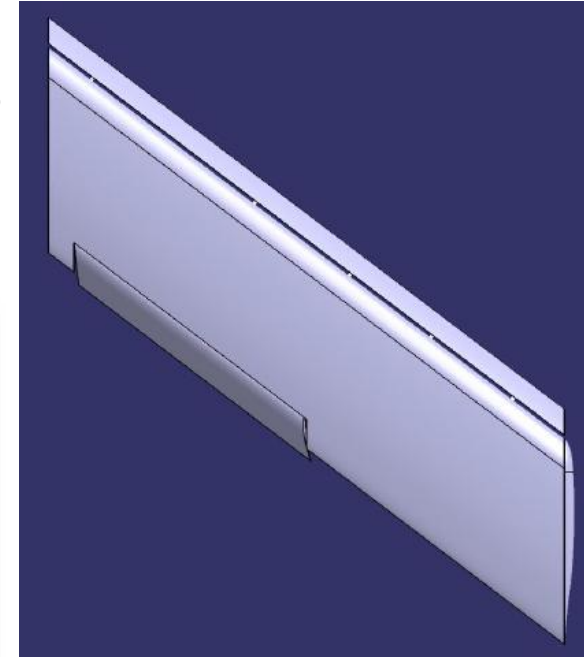
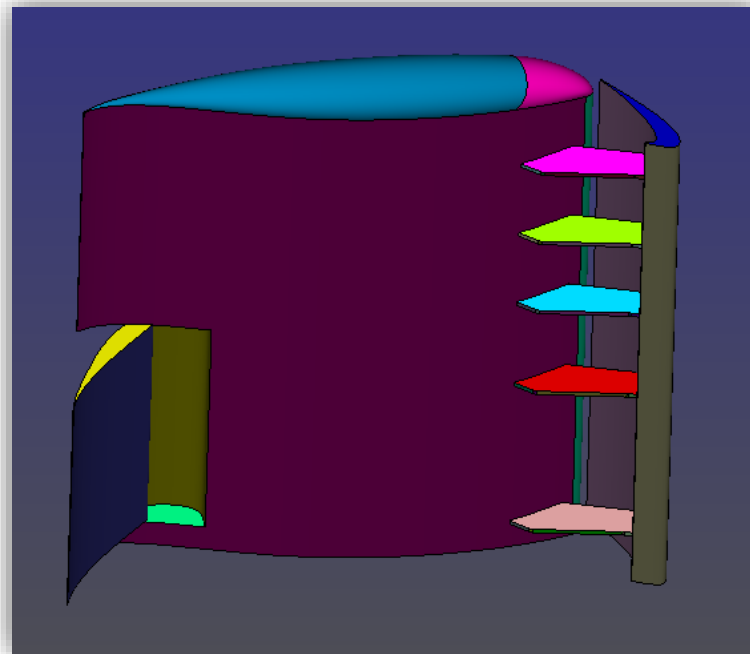
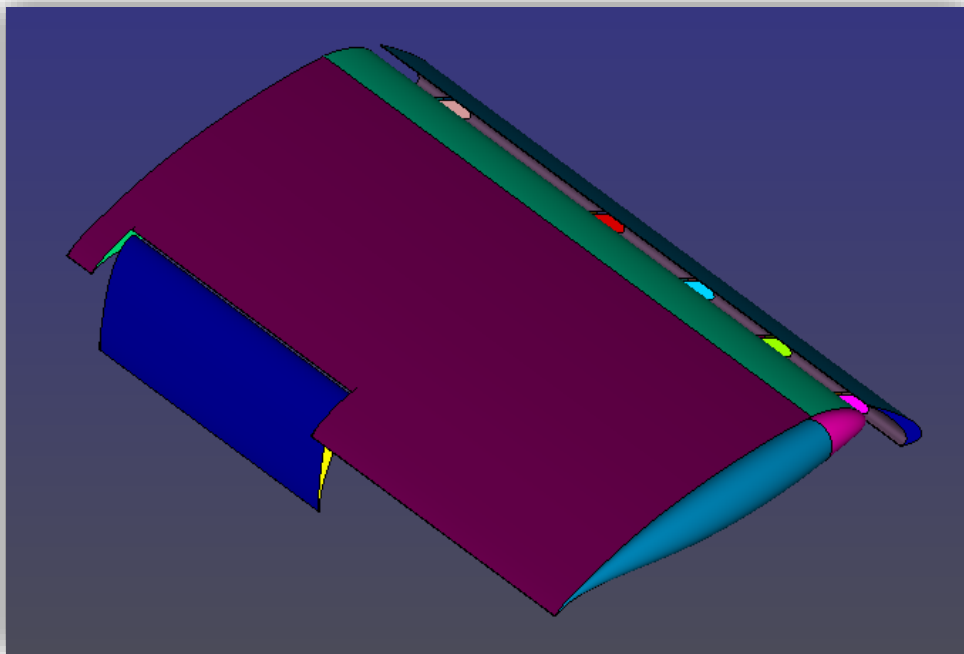

CRM-HLS

Surface Meshing *Recipe*

- Defining Surface Mesh Recipe based on “Best Practices”
- **Automatic Surface Mesh (ASM) – Baseline (Lvl-B):**
 - **Global:**
 - Max. Edge Length = 0.5 inches (1.66% C_{REF})
 - Curvature Resolution = 15 deg
 - Max. Aspect Ratio = 40
 - Growth Rate = 1.2 (unless locally adjusted)
 - Quad Dominant Algorithm
 - **Surfaces:**
 - Mapping: 6 subdivisions or cells (equal distribution) applied to all TE surfaces
 - Resolution: Applied target edge lengths of 0.075 (0.25% C_{REF}) to slat brackets
 - **Boundaries:**
 - Slat LE: 5 deg, GR = 1.1, 10 constant layers
 - WUSS LE: 5 deg, GR = 1.1, 30 constant layers
 - Flap LE: 5 deg, GR = 1.1, 10 constant layers
 - Wing Tip: 5 deg

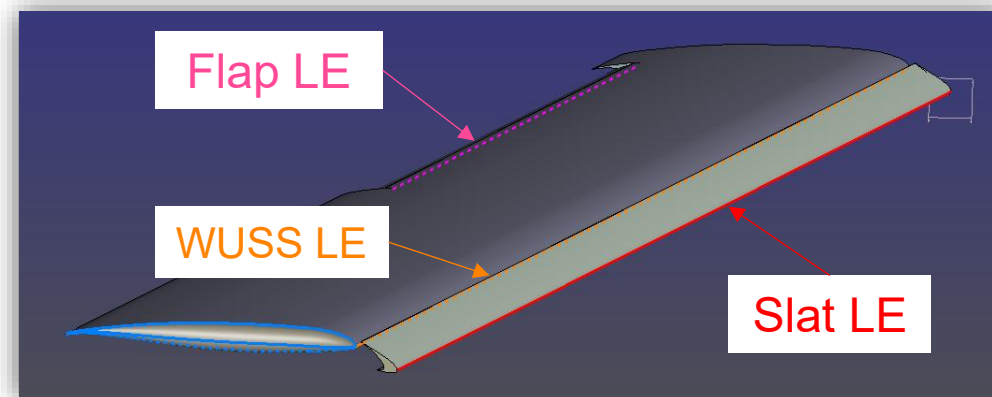
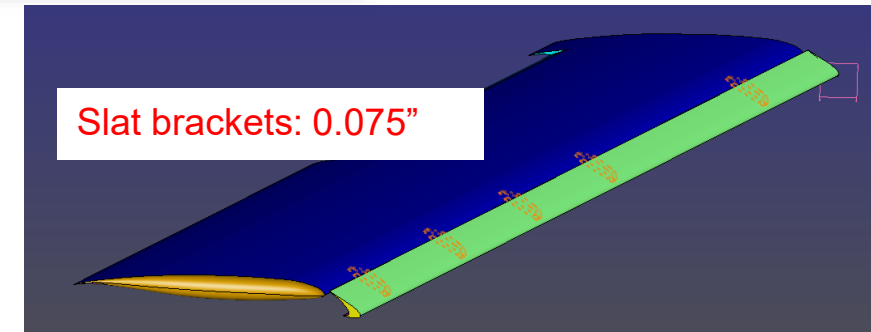
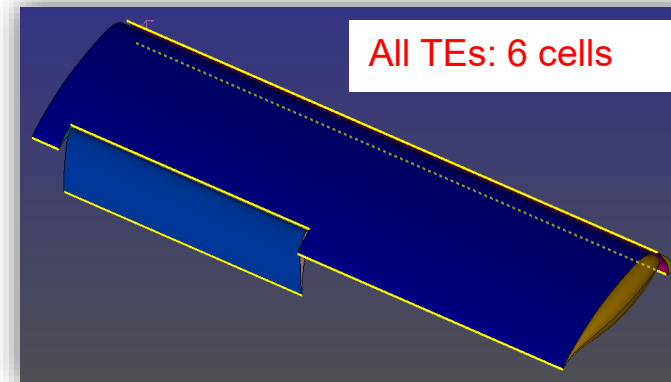

CRM-HLS

Targeted Surface and Volume Mesh Refinement

- Source shapes are created along the wake of each slat bracket
- Wake angles are re-adjusted based on the preliminary RANS solutions

Baseline (Lvl-B)

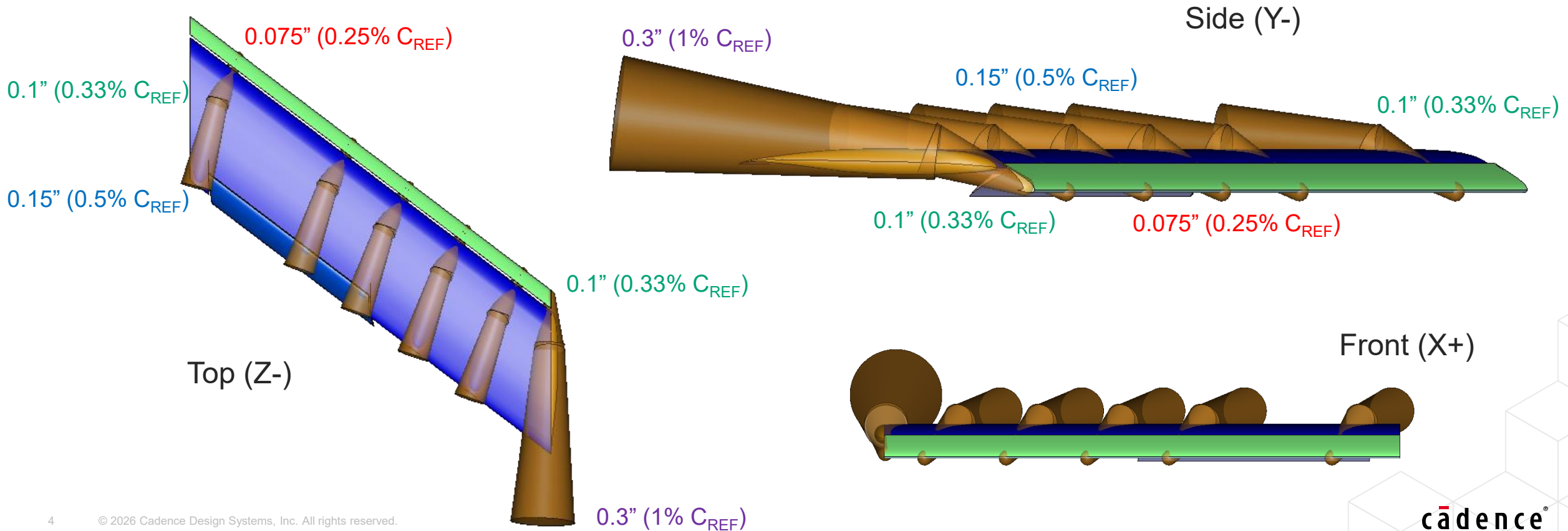

CRM-HLS

Surface Meshing

- Defining Surface Mesh Recipe based on “Best Practices”
- **Automatic Surface Mesh (ASM) – Baseline (Lvl-B):**
 - **Boundaries:**
 - **Slat LE:** 5 deg, GR = 1.1, 10 constant layers
 - WUSS LE: 5 deg, GR = 1.1, 30 constant layers
 - Flap LE: 5 deg, GR = 1.1, 10 constant layers
 - Wing Tip: 5 deg

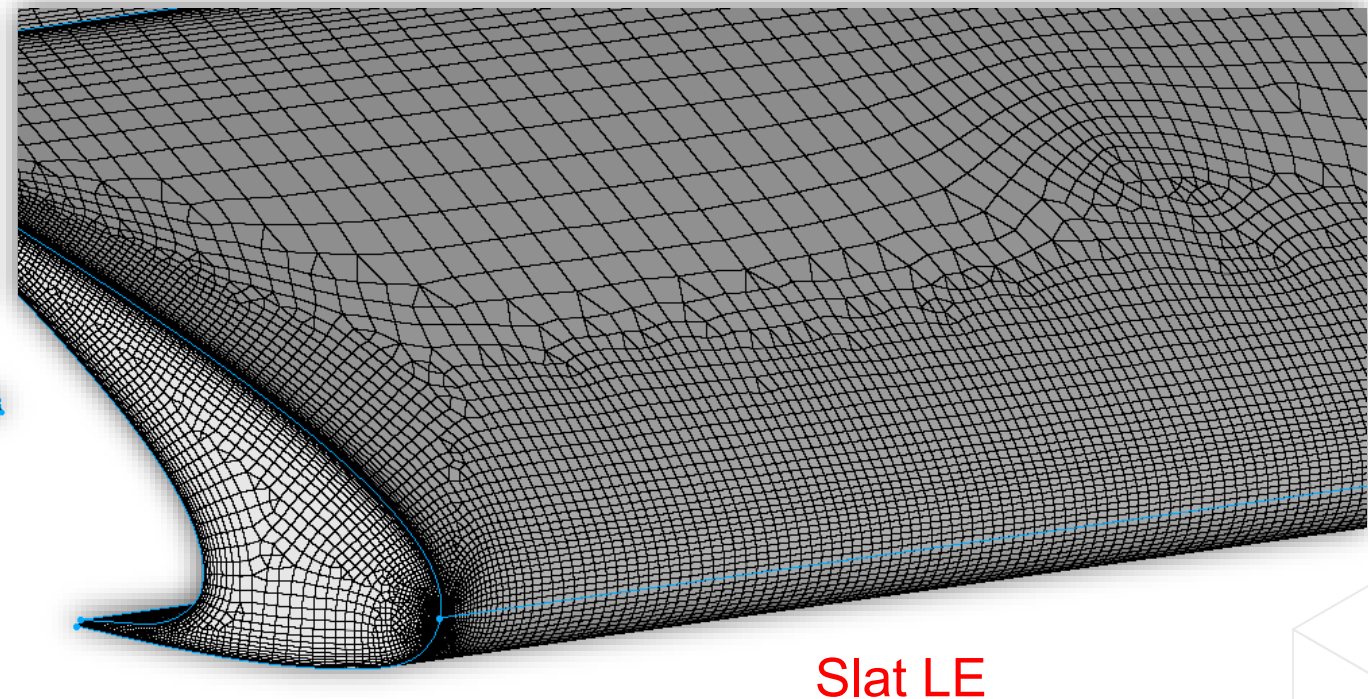
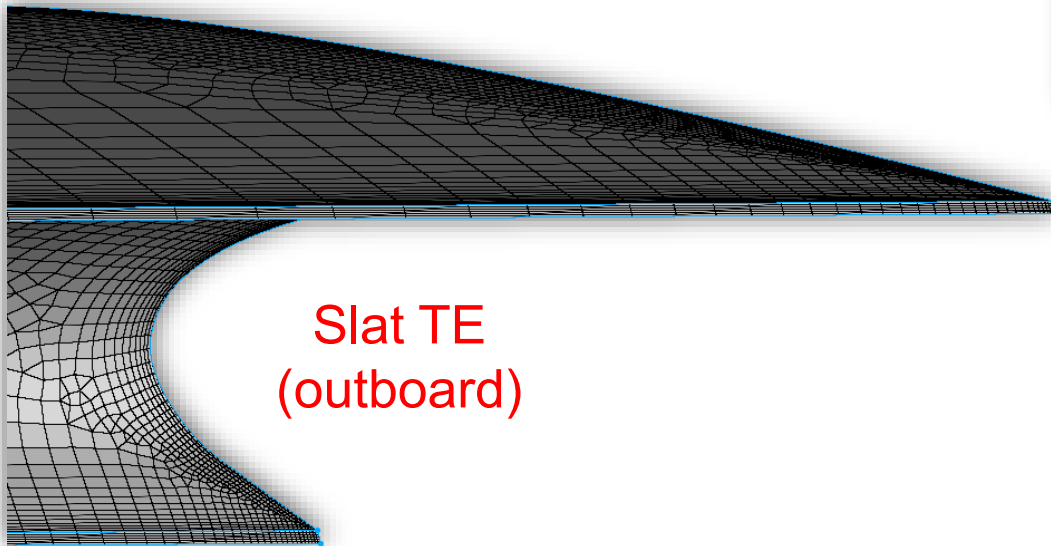
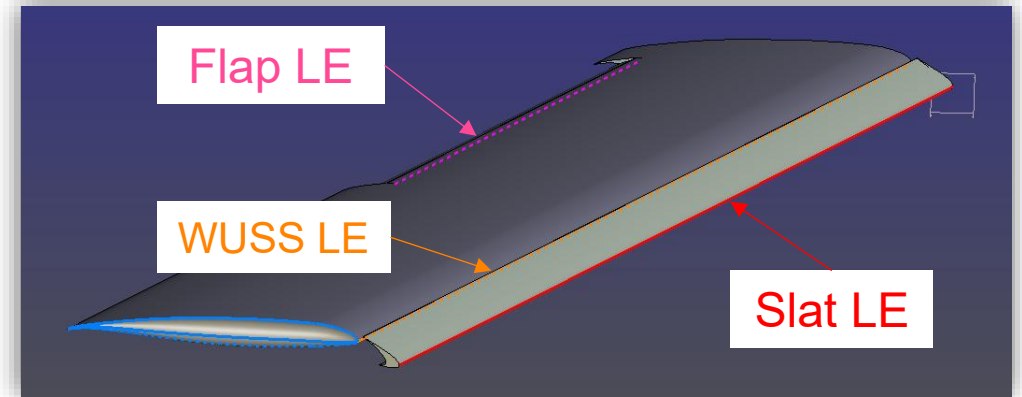

CRM-HLS

Surface Meshing

- Defining Surface Mesh Recipe based on “Best Practices”
- **Automatic Surface Mesh (ASM) – Baseline (Lvl-B):**
 - **Boundaries:**
 - **Slat LE:** 5 deg, GR = 1.1, 10 constant layers
 - **WUSS LE:** 5 deg, GR = 1.1, 30 constant layers
 - Flap LE: 5 deg, GR = 1.1, 10 constant layers
 - Wing Tip: 5 deg

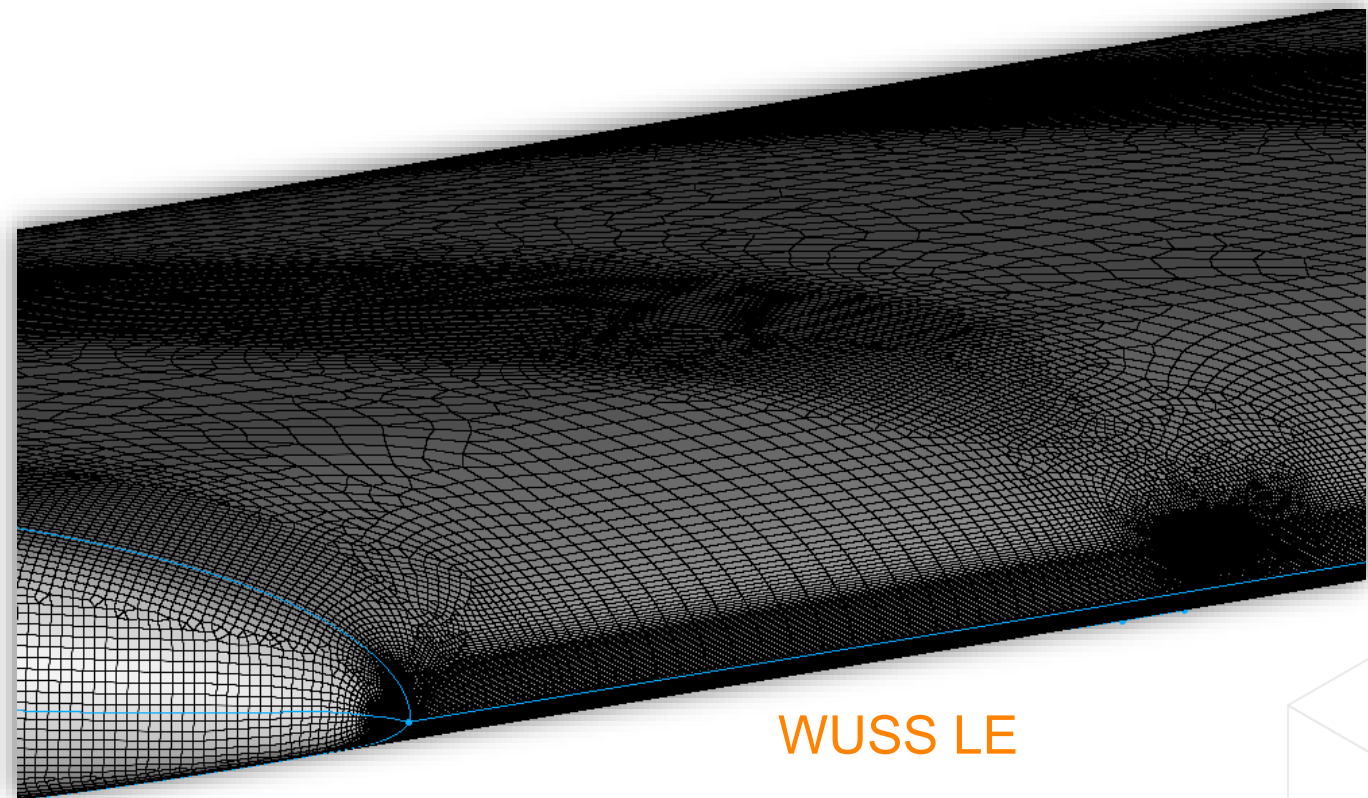
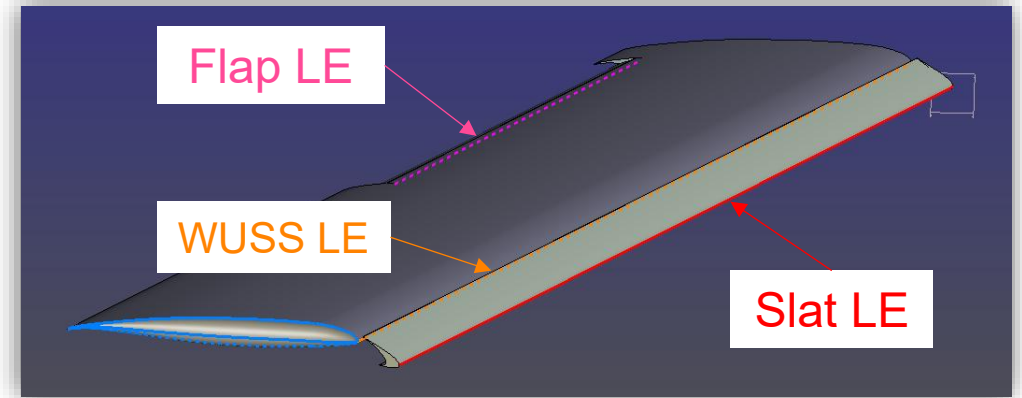
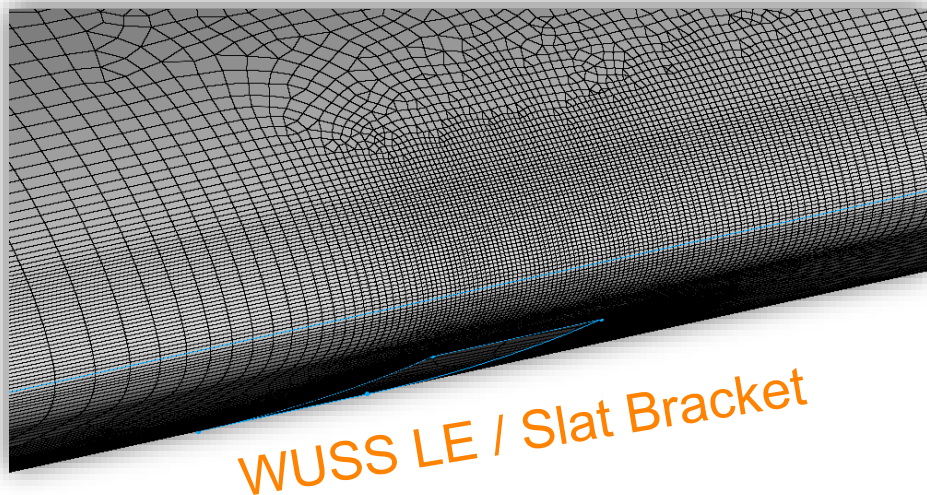

CRM-HLS

Surface Meshing

- Defining Surface Mesh Recipe based on “Best Practices”
- **Automatic Surface Mesh (ASM) – Baseline (Lvl-B):**
 - **Boundaries:**
 - **Slat LE:** 5 deg, GR = 1.1, 10 constant layers
 - **WUSS LE:** 5 deg, GR = 1.1, 30 constant layers
 - **Flap LE:** 5 deg, GR = 1.1, 10 constant layers
 - Wing Tip: 5 deg

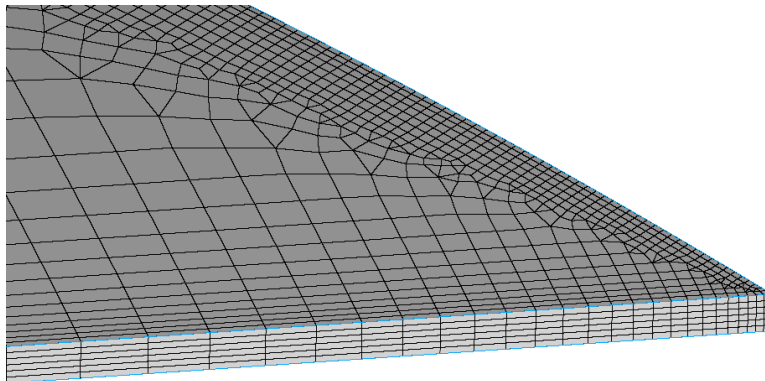
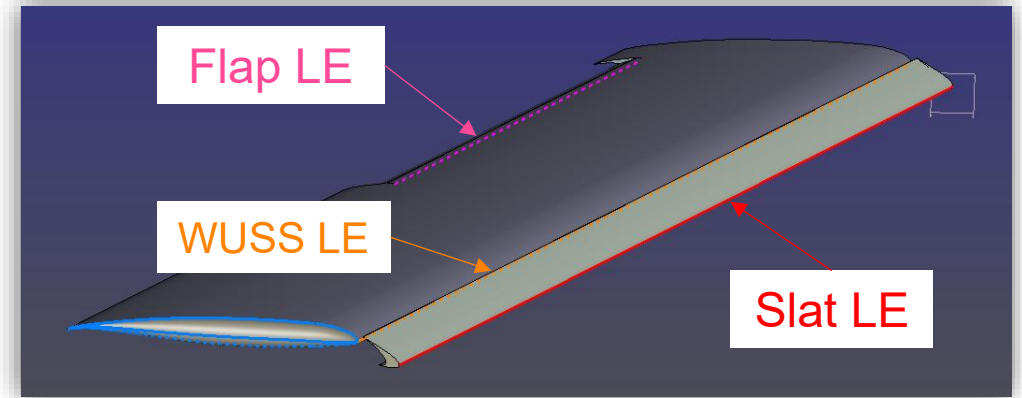

Flap TE

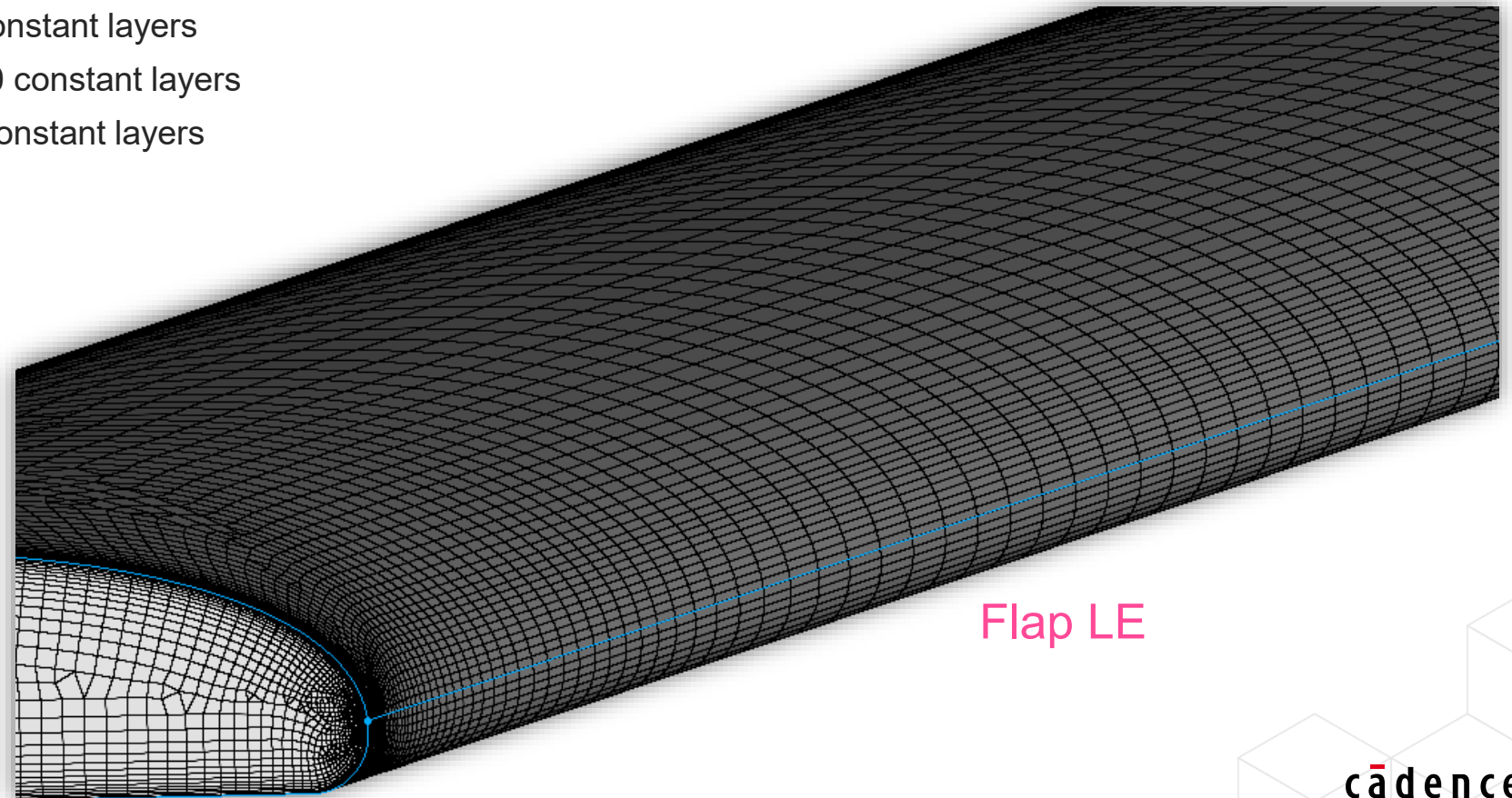

Flap LE

CRM-HLS

Surface Meshing

- Targeted Surface Mesh Refinement

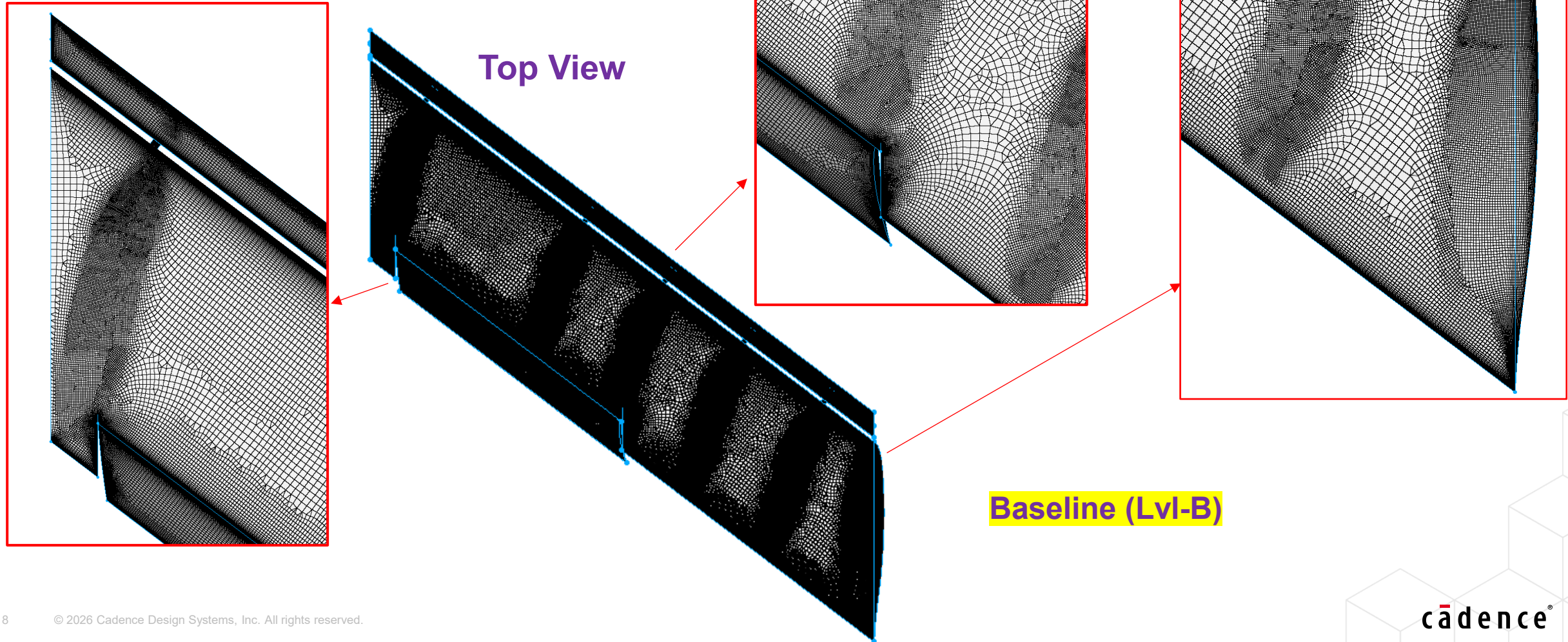

CRM-HLS

Surface Meshing

Baseline (Lvl-B)

- Targeted Surface Mesh Refinement

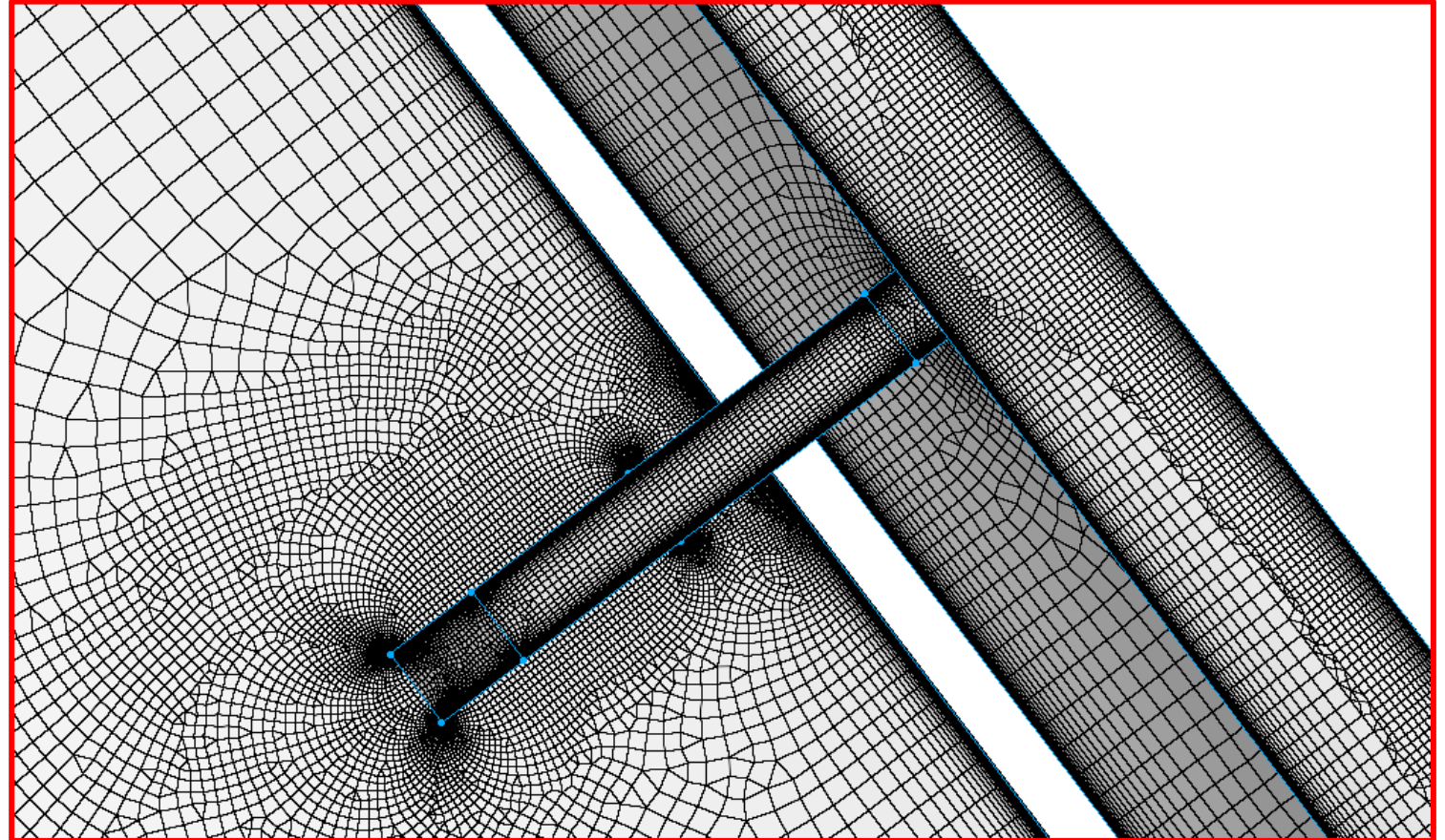
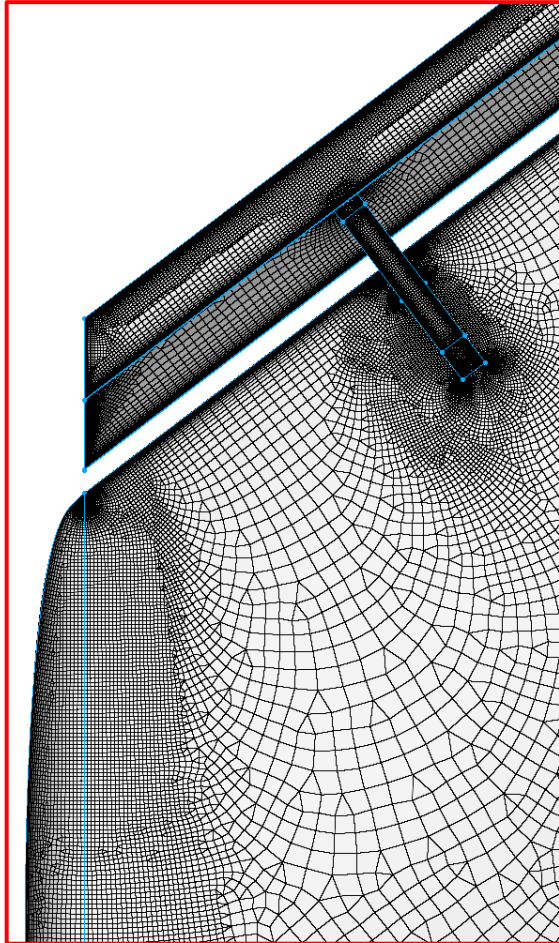





Bottom View: Middle Slat Bracket

**Bottom View:
Wing Tip / Slat-Brkt #5**

CRM-HLS

Volume Meshing

- Family 1: HexVoxel
 - Quad Dominant Surface Mesh + Voxel Farfield
 - Levels A through E are available
 - Boundary layer growth rate = 16% (Lvl-B) and scaled with the refinement factor for other grid levels.
 - Growth profile: 1.0 1.0 1.16 1.16 1.16 ...
(example for Lvl-B)

Type	Color	Count
Tets		16,027,916
Pyramids		2,542,107
Prisms		811,092
Hexes		24,136,232
All		43,517,347

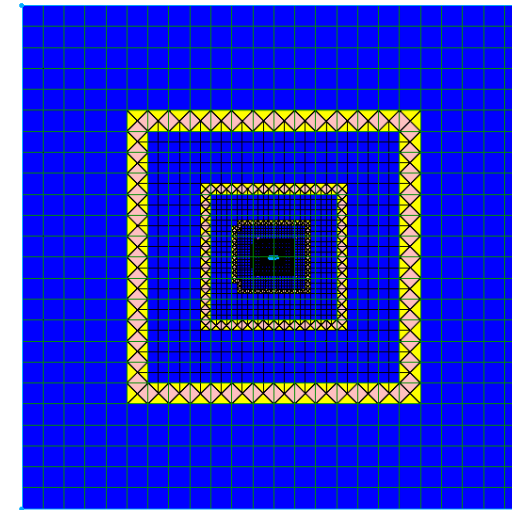

Symmetry Plane View

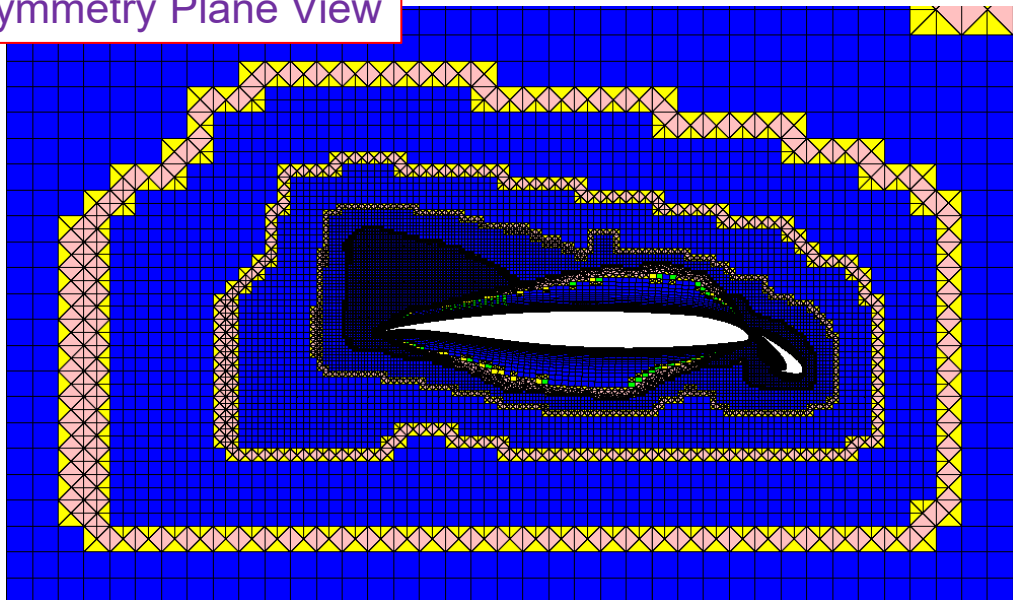

Flap Mid-Span View

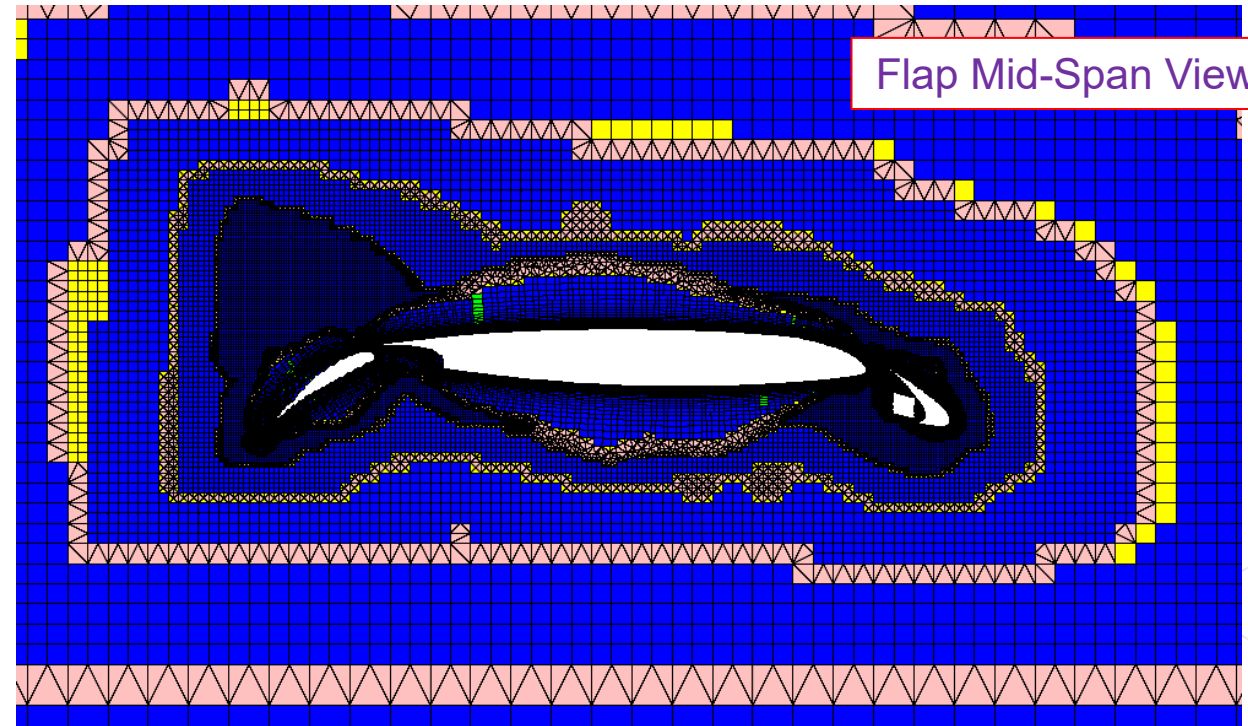

CRM-HLS

Volume Meshing

Lvl-B: Flap Mid-Span View

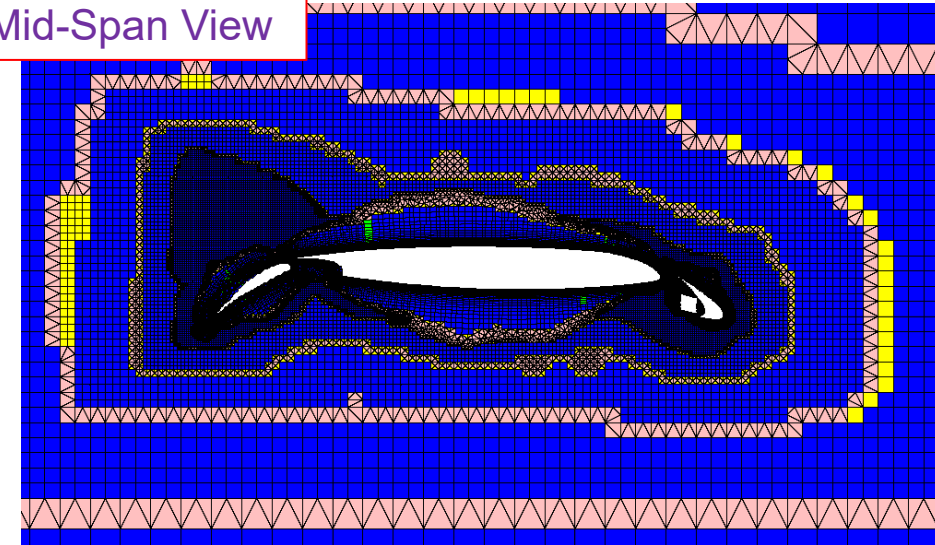





- Family 1: HexVoxel
 - Quad Dominant Surface Mesh + Voxel Farfield
 - Levels A through E are available

Grid Level	Cell Count	Node Count	Refinement Factor	Target y^+
A	25,435,031	15,520,444	0.75	4/3
B	43,517,347	28,289,287	1.0	1.0
C	106,410,939	75,726,976	1.5	2/3
D	237,759,230	180,918,004	2.0	0.5
E	568,667,444	457,688,006	3.0	1/3

CRM-HLS

Volume Meshing

- Family 2: HexIsoTet
 - Quad Dominant Surface Mesh + IsoTet Farfield
 - Levels A through E are available
 - Boundary layer growth rate = 16% (Lvl-B) and scaled with the refinement factor for other grid levels.
 - Growth profile: 1.0 1.0 1.16 1.16 1.16 ...
(example for Lvl-B)

Type	Color	Count
Tets		25,315,880
Pyramids		978,189
Prisms		796,642
Hexes		19,419,165
All		46,509,876

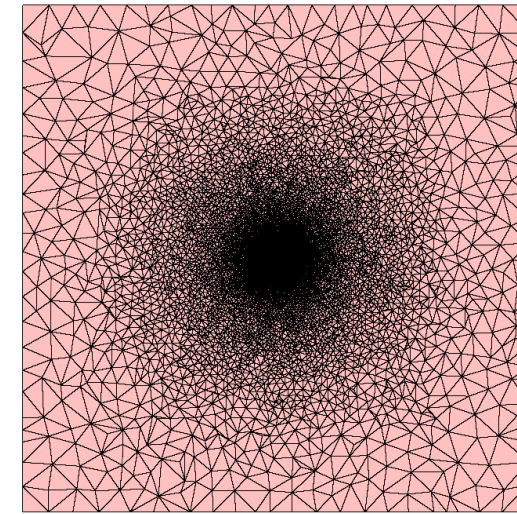

Symmetry Plane View

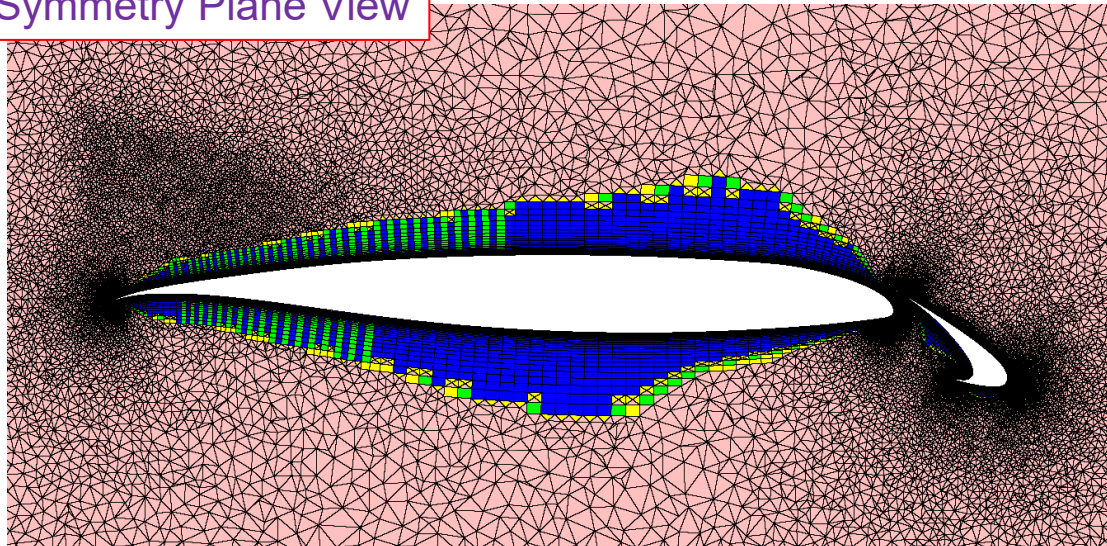

Flap Mid-Span View

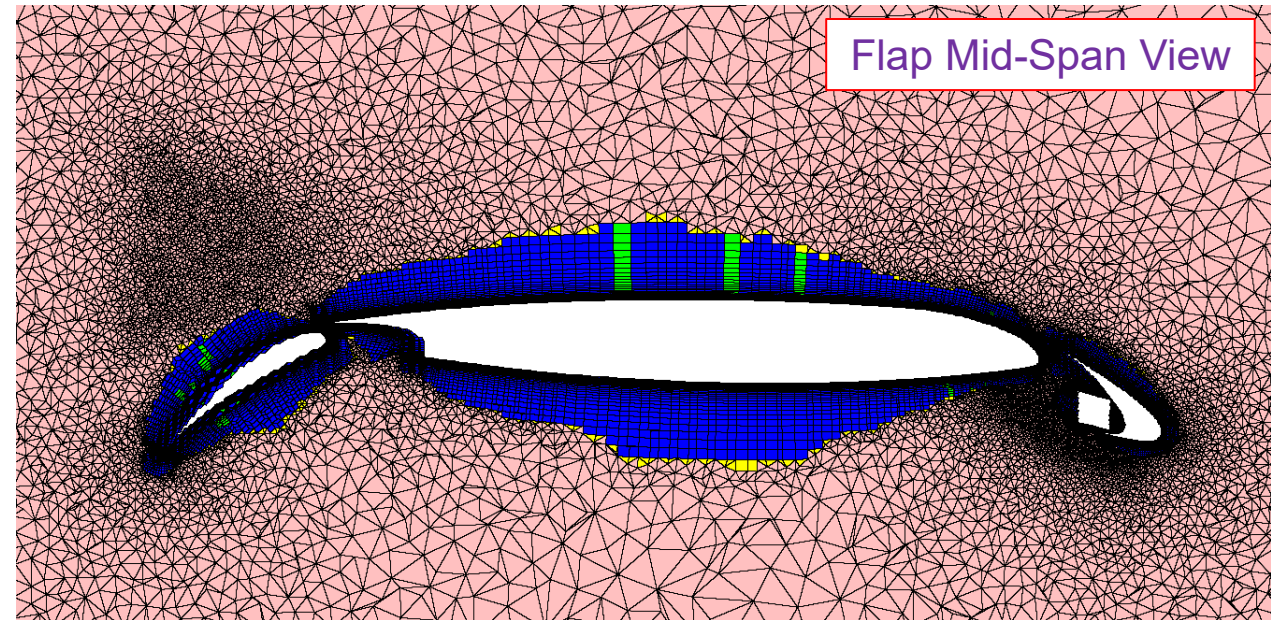

CRM-HLS

Volume Meshing

Lvl-B: Flap Mid-Span View

- Family 2: HexIsoTet
 - Quad Dominant Surface Mesh + IsoTet Farfield
 - Levels A through E are available

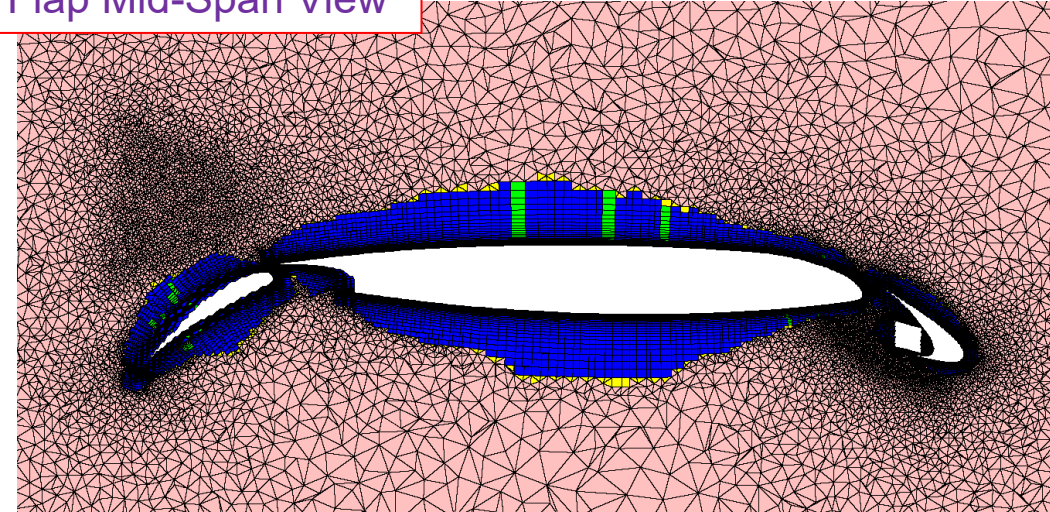

Grid Level	Cell Count	Node Count	Refinement Factor	Target y^+
A	27,208,818	13,428,913	0.75	4/3
B	46,509,876	24,570,112	1.0	1.0
C	116,911,995	66,940,962	1.5	2/3
D	265,665,810	164,250,168	2.0	0.5
E	678,260,498	418,801,298	3.0	1/3

HLPW6-TC1: CRM-HLS

Summary

- Two grid families are generated and made available for the CRM-HLS configuration
- Mesh recipe for the baseline mesh is defined based on best practices, experience from past workshops, preliminary RANS solutions, and grid sensitivity analysis
- Grid family 1 (F1) utilizes a quad-dominant surface (leading to hex-dominant boundary layer mesh) followed with the Voxel (hexCore) meshing technique in the off-body region
- Grid family 2 (F2) utilizes the same surface meshing strategy but uses isotropic tetrahedra meshing for the farfield region
- Meshes are provided in both CGNS and UGRID (b8.ugrid/mapbc) formats.

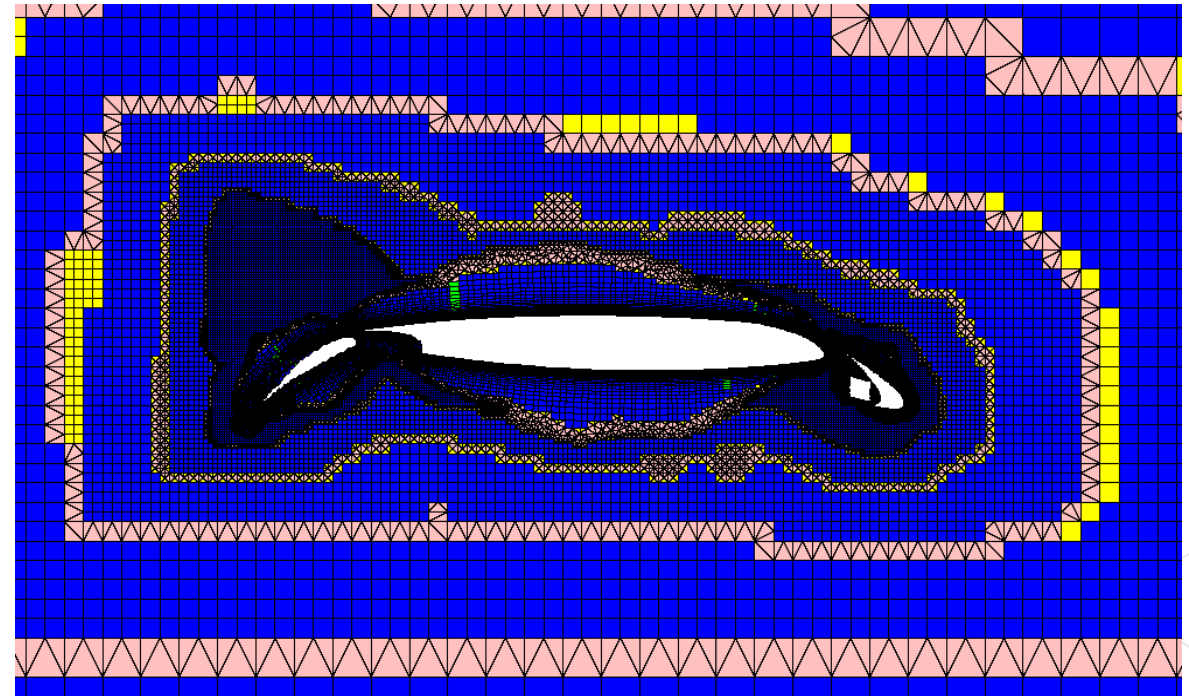
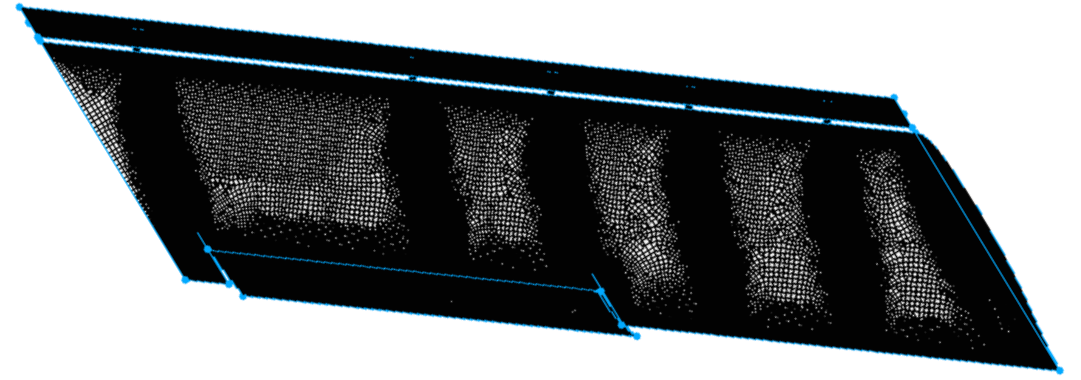

HLPW6-TC1: CRM-HLS

Summary

- Meshes are available on the HLPW6 website.
- If any TFG participants wish to collaborate on specific variations of the meshes or alternate mesh characteristics, please feel free to reach out to our team.
- Our team also plans on providing additional grid families based on alternative meshing strategies.
- We can also provide **poly** versions of these meshes:
 - T-Rex transition poly + Voxel poly
 - T-Rex transition poly + IsoTet poly

We welcome feedback!
For any questions, please reach out
via email to rezadj@cadence.com

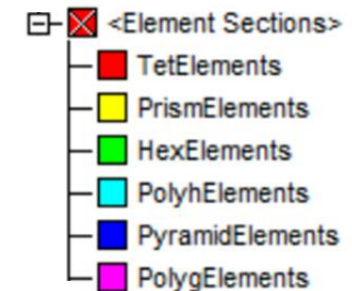
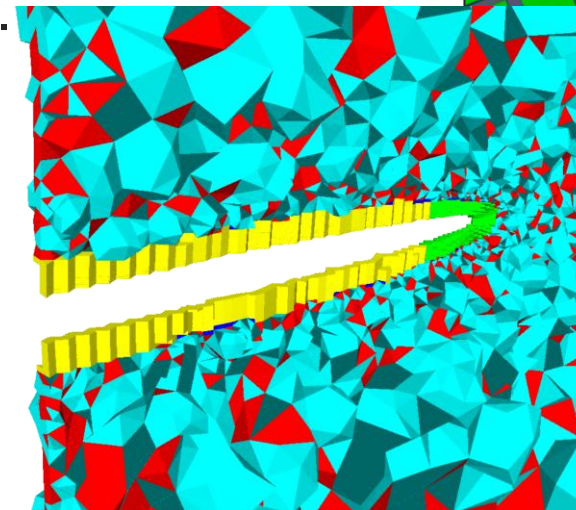
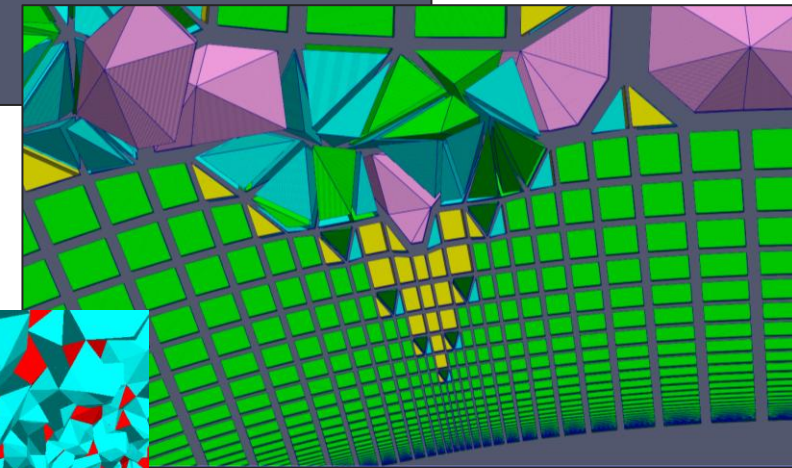
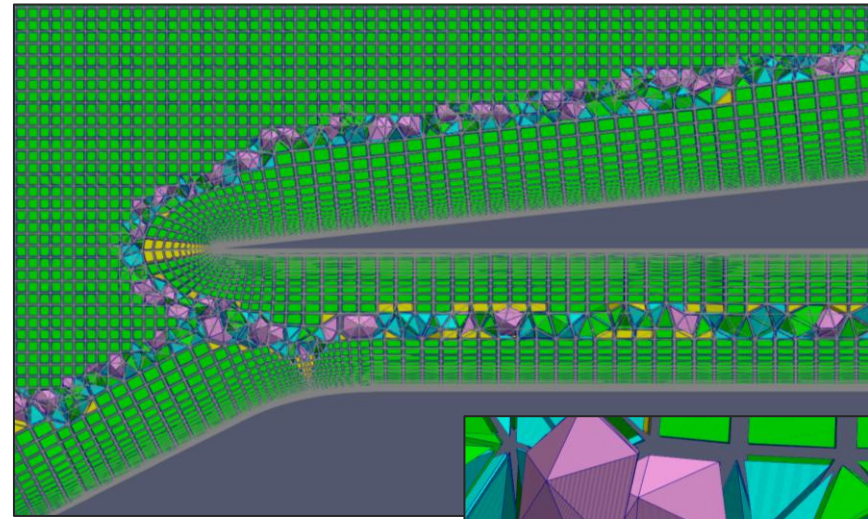



cādence®

© 2026 Cadence Design Systems, Inc. All rights reserved worldwide. Cadence, the Cadence logo, and the other Cadence marks found at <https://www.cadence.com/go/trademarks> are trademarks or registered trademarks of Cadence Design Systems, Inc. Accellera and SystemC are trademarks of Accellera Systems Initiative Inc. All Arm products are registered trademarks or trademarks of Arm Limited (or its subsidiaries) in the US and/or elsewhere. All MIPI specifications are registered trademarks or service marks owned by MIPI Alliance. All PCI-SIG specifications are registered trademarks or trademarks of PCI-SIG. All other trademarks are the property of their respective owners.